

Atuador Pneumático Perfilado/Tirantado ISO15552 *Série CPME /CTE*



Vantagens

- Raspador frontal em PU
- Vedação em Viton 180°C (opcional)
- Robustez e Durabilidade
- Curso máx. 2000mm
- Perfil para montagem direta de Sensor
- Rosca da Haste com tratamento Anti corrosão



Características Técnicas

Ø cilindro (mm)	32	40	50	63	80	100	125	160	200	250	320
Ø haste (mm)	12	16	20		25		32	40		50	60
Rosca da haste	M10x1.25	M12x1.25	M16x1.5		M20x1.5		M27x2	M36x2		M42x2	M48x2
Conexão	G1/8"	G1/4"	G1/4"	G3/8"	G3/8"	G1/2"	G1/2"	G3/4"		G1"	
Pressão de trabalho (bar)	1 ~ 9 bar										
Pressão máx. de trabalho (bar)	13,5 bar										
Temperatura de trabalho (°C)	-5°C ~ 70°C									-10°C ~ 80°C	
Velocidade de trabalho (mm/s)	50 ~ 800mm/s									50 ~ 300mm/s	
Lubrificação	Não necessária										

Simbologia:

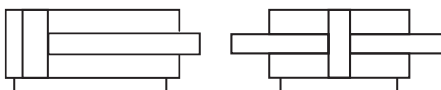

Codificação

C	<input type="text"/>	E	<input type="text"/>	-	<input type="text"/>	<input type="text"/>	-	<input type="text"/>
Modelo		Ø (mm)	Curso (mm)		Vedação		Haste	
PM	Perfilado	32	Máx. 2000		-	NBR	-	Simples
T	Tirantado	40			V	Viton (180°C)	P	Passante
		50					I	Inox
		63						
		80						
		100						
		125						
		160*						
		200*						
		250*						
		320*						

*Ø160 ~ 320mm somente no modelo Tirantado

Exemplo:

CPME40-500 - Atuador Perfilado, Ø40mm, Curso 500mm, Vedação NBR, Haste Simples

CPME63-200-P - Atuador Perfilado. Ø63mm, Curso 200mm, Vedação NBR, Haste Passante

CTE50-100V - Atuador Tirantado, Ø50mm - Curso 100mm. Vedação Viton, Haste Simples

Tabela de Força Teórica

Unidade: N

CILINDRO Ø (mm)	HASTE Ø (mm)	SENTIDO DO MOVIMENTO	ÁREA EFECTIVA (mm ²)	PRESSÃO DE TRABALHO DA LINHA								
				2	3	4	5	6	7	8	9	10
32	12	AVANÇO	804,25	160,85	241,28	321,70	402,13	482,55	562,98	643,40	723,83	804,25
		RETORNO	691,15	138,23	207,35	276,46	345,58	414,69	483,81	552,92	622,04	691,15
40	16	AVANÇO	1256,64	251,33	376,99	502,66	628,32	753,98	879,65	1005,31	1130,98	1256,64
		RETORNO	1055,58	211,12	316,67	422,23	527,79	633,35	738,91	844,46	950,02	1055,58
50	20	AVANÇO	1963,5	392,70	589,05	785,40	981,75	1178,10	1374,45	1570,80	1767,15	1963,50
		RETORNO	1055,58	211,12	316,67	422,23	527,79	633,35	738,91	844,46	950,02	1055,58
63	20	AVANÇO	3117,25	623,45	935,18	1246,90	1558,63	1870,35	2182,08	2493,80	2805,53	3117,25
		RETORNO	2809,1	561,82	842,73	1123,64	1404,55	1685,46	1966,37	2247,28	2528,19	2809,10
80	25	AVANÇO	5026,56	1005,31	1507,97	2010,62	2513,28	3015,94	3518,59	4021,25	4523,90	5026,56
		RETORNO	4535,68	907,14	1360,70	1814,27	2267,84	2721,41	3174,98	3628,54	4082,11	4535,68
100	25	AVANÇO	7854	1570,80	2356,20	3141,60	3927,00	4712,40	5497,80	6283,20	7068,60	7854,00
		RETORNO	7363,12	1472,62	2208,94	2945,25	3681,56	4417,87	5154,18	5890,50	6626,81	7363,12
125	32	AVANÇO	12271,87	2454,37	3681,56	4908,75	6135,94	7363,12	8590,31	9817,50	11044,68	12271,87
		RETORNO	11467,62	2293,52	3440,29	4587,05	5733,81	6880,57	8027,33	9174,10	10320,86	11467,62
160	40	AVANÇO	20106,24	4021,25	6031,87	8042,50	10053,12	12063,74	14074,37	16084,99	18095,62	20106,24
		RETORNO	18849,6	3769,92	5654,88	7539,84	9424,80	11309,76	13194,72	15079,68	16964,64	18849,60
200	40	AVANÇO	31416	6283,20	9424,80	12566,40	15708,00	18849,60	21991,20	25132,80	28274,40	31416,00
		RETORNO	30159,36	6031,87	9047,81	12063,74	15079,68	18095,62	21111,55	24127,49	27143,42	30159,36

Sensor Aplicável

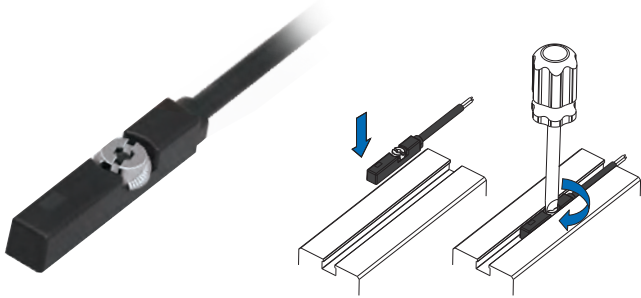

SM-65

Tipo		Cabo	
R	Reed (2 fios)	3M	3 metros
P	PNP (3 fios)	M8	Conector M8
N	NPN (3 fios)		
RP	Reed (3 fios)		

MODELO	SM-65R	SM-65N	SM-65P	SM-65RP
Diagrama				
Características				
Método de Fiação	2 Fios	3 Fios		
Lógica	SPST	Solid State Output		SPST
Tipo de Sensor	Reed Switch	NPN	PNP	Reed Switch
Tensão de Operação	5~240V DC/AC	10~28V DC		10~30V DC/AC
Corrente	100mA max.	200mA max.		500mA max.
Contato	10W max.	5.5W max.		10W max.
Consumo Atual	-	10mA @ 24V DC max.		10mA @ 24V DC max.
Queda de Voltagem	3.0V max.	1.5V max.		0.1V @ 100mA max.
Fuga de Corrente	-	0.05mA max.		-
Indicador (LED)	Vermelho		Amarelo	
Cabo	ø2.8, 2C, PUR	ø2.8, 3C, PUR		
Frequência	200Hz	1000Hz max.		200Hz
Exigência de Imã	75Gauss	50Gauss		65Gauss
Temperatura	-10~70°C			
Choque	30G	50G		30G
Vibração	9G			
Classificação	IEC 60529 IP67			
Circuito de Proteção	1	2,3,4		1

• CONECTOR M8

• SM-65N / SM-65P

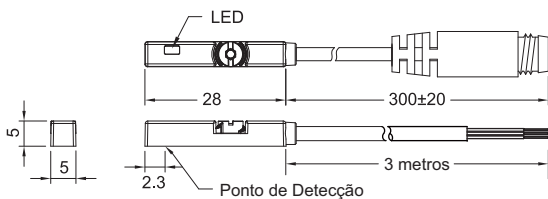

• Canal da camisa

• SM-65R / SM-65RP

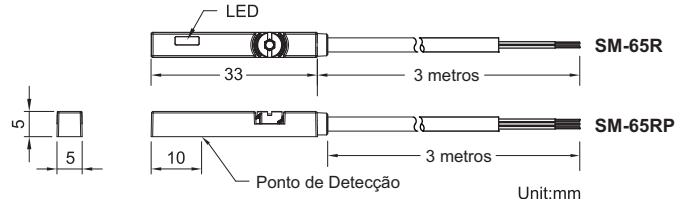

Construção

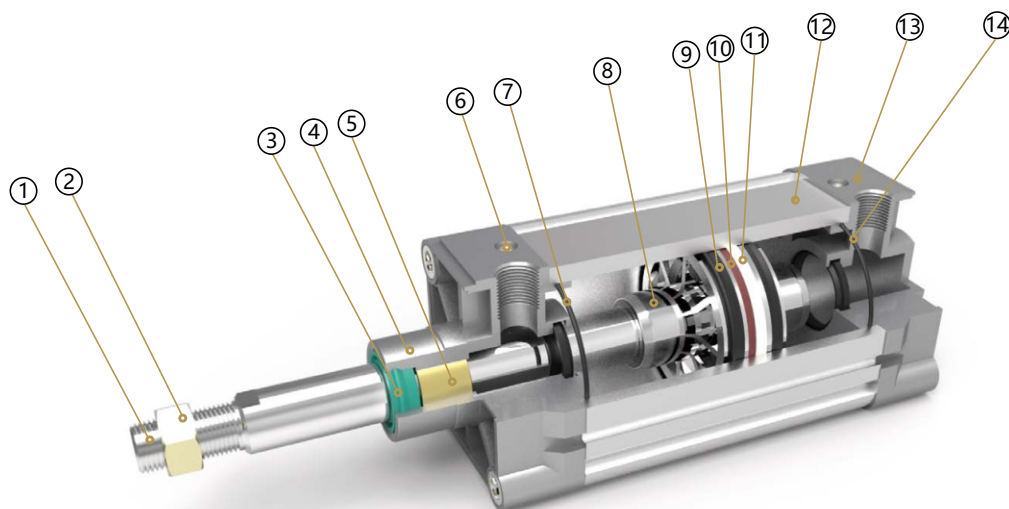

Número	Nome	Número	Nome
1	Haste	8	Amortecedor
2	Porca Hexagonal	9	Gaxeta
3	Vedação do Eixo	10	Imã
4	Tampa Dianteira	11	Anel Raspador
5	Tubo de Cobre	12	Camisa
6	Parafuso de Ajuste Amortecimento	13	Tampa Traseira
7	O ring de Vedação	14	O ring de Vedação

Kit Reparo

Kit Reparo		
Ø cilindro	Código	Compõe o kit
32	KR-CPKIT32	Raspador dianteiro; Vedação do êmbolo; Vedação das tampas.
40	KR-CPKIT40	
50	KR-CPKIT50	
63	KR-CPKIT63	
80	KR-CPKIT80	
100	KR-CPKIT100	
160	KR-CTEKIT160	
200	KR-CTEKIT200	
250	KR-CTEKIT250	
320	KR-CTEKIT320	

Kit Reparo para Cilindro Haste Passante		
Ø cilindro	Código	Compõe o kit
32	KR-CPKIT32P	Raspadores; Vedação do êmbolo; Vedação das tampas.
40	KR-CPKIT40P	
50	KR-CPKIT50P	
63	KR-CPKIT63P	
80	KR-CPKIT80P	
100	KR-CPKIT100P	
160	KR-CTEKIT160P	
200	KR-CTEKIT200P	
250	KR-CTEKIT250P	
320	KR-CTEKIT320P	

Dimensional

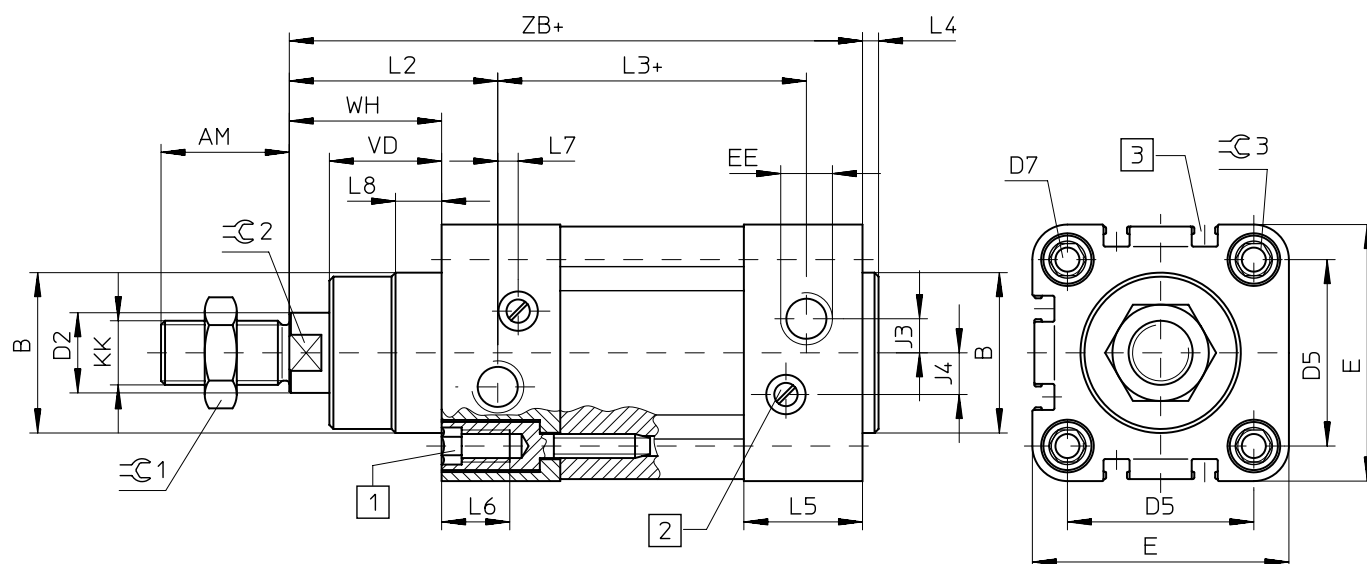

Ø do cilindro mm	AM	B Ø d11	D2 Ø f8	D5	D7	E	EE	J3	J4	KK	L2
32	22	30	12	32.5	M6	45	G1/8	6	5.2	M10 x 1.25	41.6
40	24	35	16	38	M6	54	G1/4	8	6	M12 x 1.25	44
50	32	40	20	46.5	M8	64	G1/4	10	8.5	M16 x 1.5	51
63	32	45	20	56.5	M8	75	G3/8	12.4	10	M16 x 1.5	54
80	40	45	25	72	M10	93	G3/8	8	12.5	M20 x 1.5	62.4
100	40	55	25	89	M10	110	G1/2	11,8	10	M20 x 1.5	69.8
125	54	60	32	110	M12	134	G1/2	13	8	M27 x 2	83

Ø do cilindro mm	L3	L4	L5	L6	L7	L8	∅2	∅3	VD	WH ±1	ZB ±0.8
32	62.8	4	25.1	16	3.3	10	10	6	18	26	120
40	77	4	29.6	16	3.6	10.5	13	6	21.5	30	135
50	78	4	29.6	17	5.1	11.5	17	8	28	37	143
63	87	4	35.6	17	6.6	15	17	8	28.5	37	158
80	95.2	4	35.9	17	10.5	15.7	22	6	34.7	46	174
100	100.4	4	38.8	17	8	19.2	22	6	38.2	51	189
125	124	6	44.7	22	14	20.5	27	8	46	65	225

Dimensional

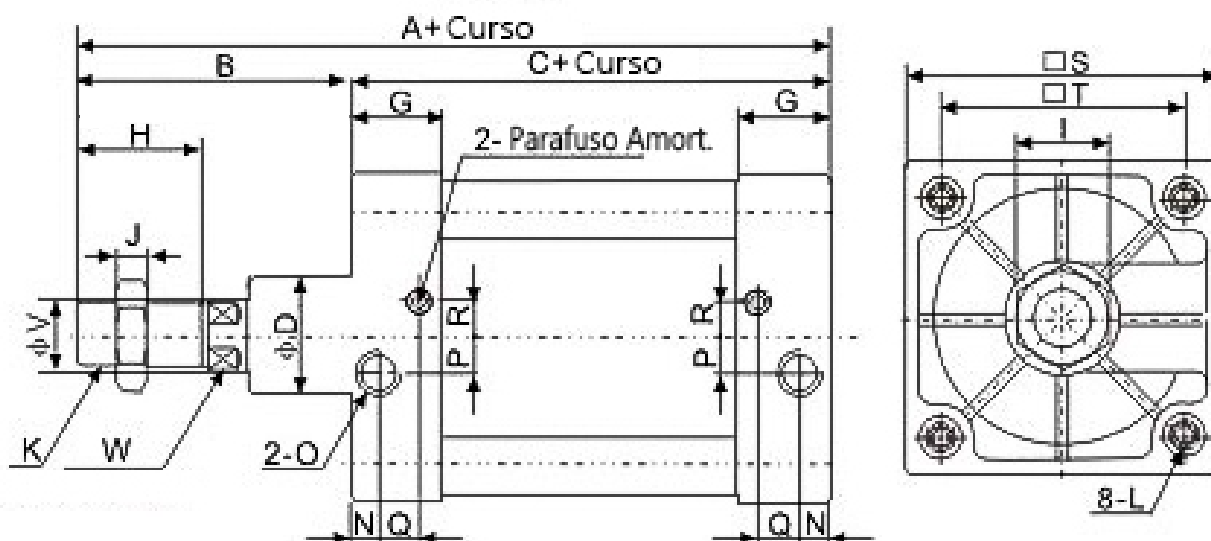

ø do cilindro mm	A	A1	A2	B	C	D	G	H	I	J
160	332	484	448	152	180	65	50	72	55	18
200	337	494	452	157	180	75	51	72	55	18

ø do cilindro mm	K	L	N	O	P	Q	R	S	T	V	W	Z
160	M36x2	M16	25	G1/2"	15	12	20	180	140	40	36	40
200	M36x2	M16	25	G3/4"	15	12	20	220	175	40	36	40

Dimensional

• Ø250mm

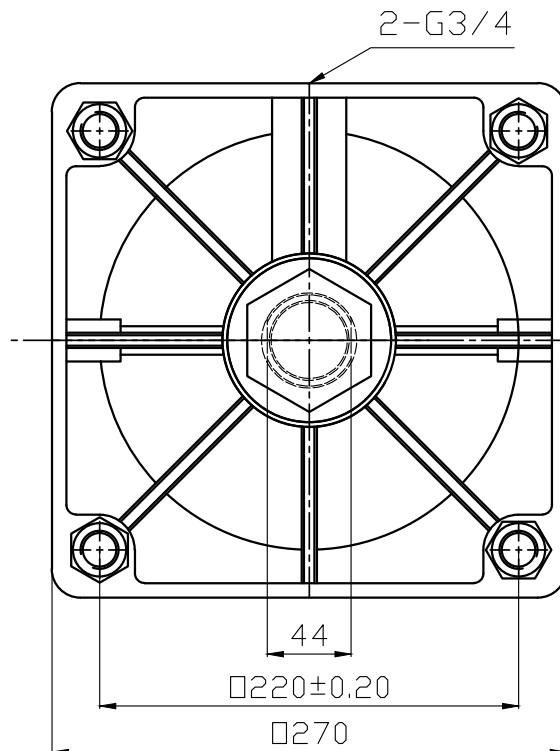
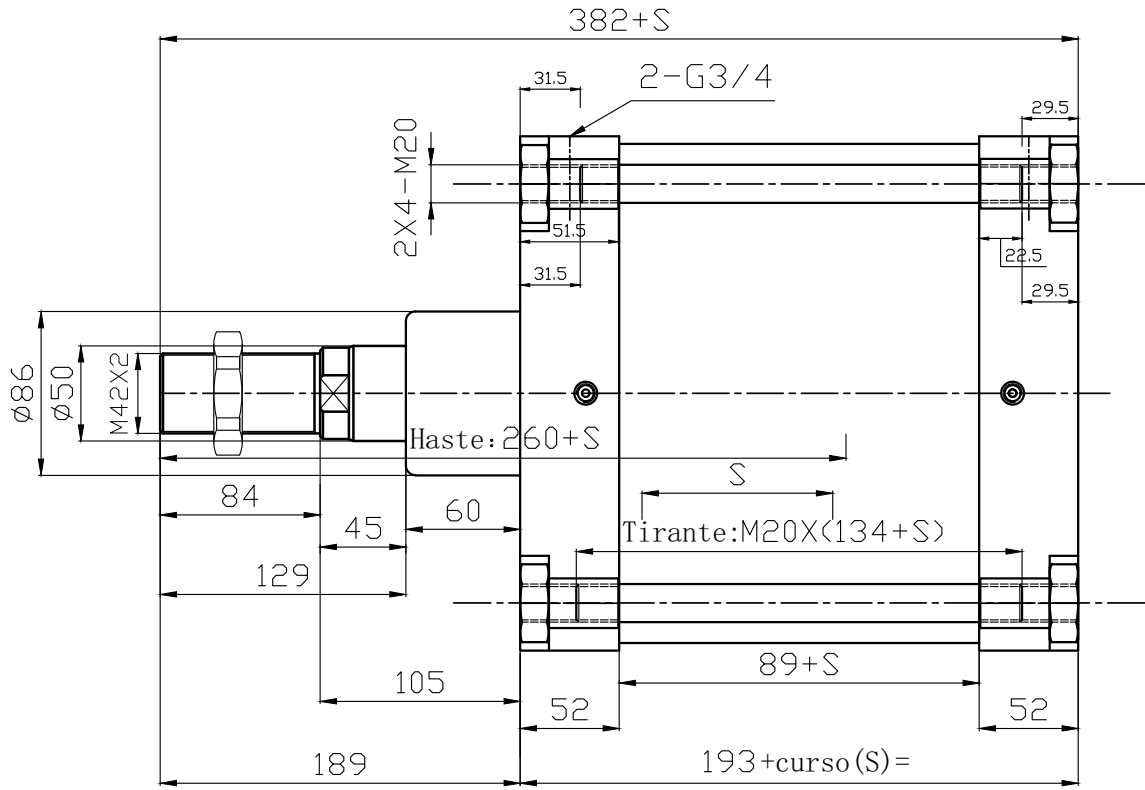

Dimensional

• Fixação tipo Pés

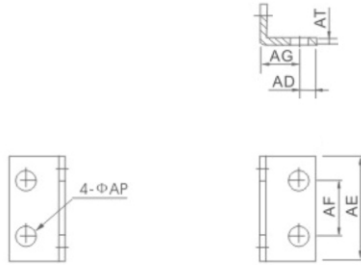

Symbol/Bore	32	40	50	63	80	100	125	160	200
AD	8	9	10	12	19	19	20	20	30
AE	47	53	65	75	95	115	140	180	220
AF	32	36	45	50	63	75	90	115	135
AG	24	28	32	32	41	45	45	60	70
AP	7	9	9	9	12	14.5	16.5	18.5	24
AT	3	3	3	3	4	4	6	6	9

• Rótula Esférica

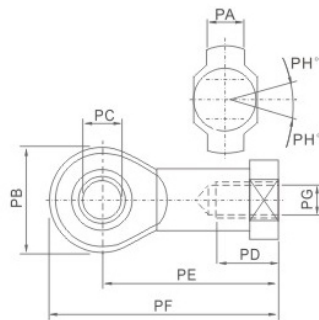

Symbol/Bore	PA	PB	PC	PD	PE	PF	PG	PH
32	11	26	10	21	43	56	M10×1.25	13
40	12	30	12	24	50	65	M12×1.25	13
50	15	38	16	33	64	83	M16×1.5	15
63	15	38	16	33	64	83	M16×1.5	15
80	18	46	20	40	77	100	M20×1.5	15
100	18	46	20	40	77	100	M20×1.5	15
125	37	70	30	51	110	145	M27×2.0	15
160	43	80	35	56	125	165	M36×2.0	16
200	43	80	35	56	125	165	M36×2.0	16

• Fixação Traseira Macho

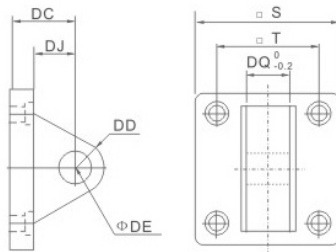

Symbol/Bore	32	40	50	63	80	100	125	160	200
S	47	53	65	75	95	115	140	180	220
T	32.5	38	46.5	56.5	72	89	110	140	175
DC	22	25	27	32	36	41	50	55	60
DD	9	12	12	15	15	20	25	30	30
DE	10	12	12	16	16	20	25	30	30
DJ	13	16	17	22	22	27	33	35.5	36
DQ	25.8	27.8	31.7	39.7	49.7	59.7	69.7	89.7	89.7

• Fixação Traseira Fêmea

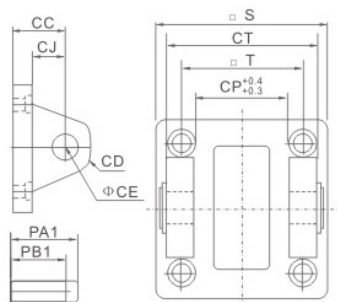

Symbol/Bore	32	40	50	63	80	100	125	160	200
CC	22	25	27	32	36	41	50	55	60
CD	9	12	12	15	15	20	25	30	30
CE	10	12	12	16	16	20	25	30	30
CJ	13	16	17	22	22	27	31	35.5	36
CP	26	28	32	40	50	60	70	90	90
CT	45	52	60	70	90	110	130	170	170
PA1	51	59	67	77	97	119	139	181	181
PB1	45.5	52.5	60.5	70.5	90.5	110.5	130.5	170.5	170.5
S	47	53	65	75	95	115	140	180	220
T	32.5	38	46.5	56.5	72	89	110	140	175

Acessórios de Montagem

Fixação tipo Pés



Código (Ø)
L32
L40
L50
L63
L80
L100
L125
L160
L200

Rótula Esférica



Código (Ø)
K25/32
K40
K50/63
K80/100
K125
K160
K200

Fixação Traseira Macho



Código (Ø)
C32
C40
C50
C63
C80
C100
C125
C160
C200

Fixação Traseira Fêmea



Código (Ø)
D32
D40
D50
D63
D80
D100
D125
D160
D200

Fixação Traseira Macho Deslocado



Código (Ø)
E32
E40
E50
E63
E80
E100
E125

Fixação Traseira Macho c/ Rótula

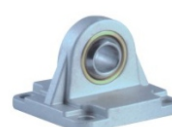

Código (Ø)
CS32
CS40
CS50
CS63
CS80
CS100

Fixação tipo Flange



Código (Ø)
F32
F40
F50
F63
F80
F100
F125
F160
F200

Munhão Frontal / Traseiro



Código (Ø)
TF32
TF40
TF50
TF63
TF80
TF100

Junta Flutuante



Código (Ø)
JF25/32
JF40
JF50/63
JF80/100
JF125
JF160/200

Garfo para Haste



Código (Ø)
G25/32
G40
G50/63
G80/100
G125
G160/200

Pino para Garfo



Código (Ø)
I-25/32
I-40
I-50/63
I-80/100
I-125
I-160/200

Fixação Traseira Macho Deslocado c/ Rótula

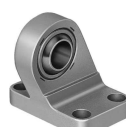

Código (Ø)
ES32
ES40
ES50
ES63
ES80
ES100
ES125
ES160
ES200

Guia Linear



Código (Ø)
GB32 / GR32
GB40 / GR40
GB50 / GR50
GB63 / GR63
GB80 / GR80
GB100 / GR100

Munhão Central Deslocável



Código (Ø)
T32
T40
T50
T63
T80
T100
T125

• Fixação Traseira Macho Deslocado



ISO-SDB Type

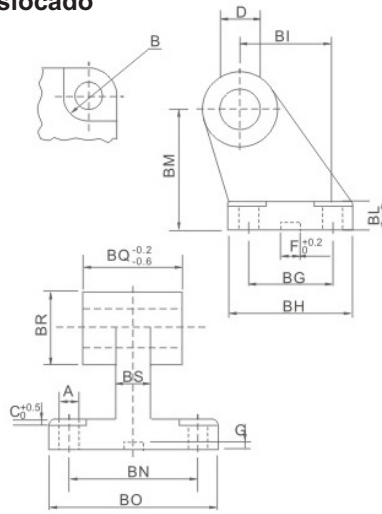

Symbol/Bore	32	40	50	63	80	100	125
A	6.6	6.6	9	9	11	11	14
B	11	11	15	15	18	18	20
BG	18	22	30	35	40	50	60
BH	31	35	45	50	60	70	90
BI	21	24	33	37	47	55	70
BL	8	10	12	14	14	17	20
BM	32	36	45	50	63	71	90
BN	38	41	50	52	66	76	94
BO	51	54	65	67	86	96	124
BS	10	15	16	16	20	20	30
BR	20	22	26	30	30	38	45
C	1.6	1.6	1.6	1.6	2.5	2.5	3.2
D	10	12	12	16	16	20	25
F	10.5	10.5	10.5	10.5	10.5	10.5	10.5
G	3	3	3	3	3	3	3
BQ	26	28	32	40	50	60	70

• Fixação Traseira Macho com Rótula Esférica

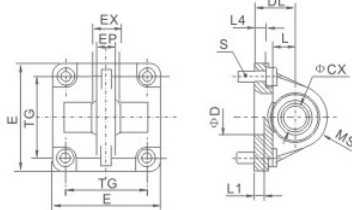

Symbol/Bore	32	40	50	63	80	100
TG	32.5	38	46.5	56.5	72	89
φCX	10	12	16	16	20	20
DL	22	25	27	32	36	41
L	12	15	15	20	20	25
EX	14	16	21	21	25	25
EP	10.5	12	15	15	18	18
S	M6×20	M6×20	M8×20	M8×20	M10×25	M10×25
L4	5.5	5.5	6.5	6.5	10	10
D	30	35	40	45	45	55
L1	7	7	7	7	9	9
E	45	52	65	75	95	115
MS	16	18	21	23	28	30

• Fixação Traseira Macho Deslocado com Rótula Esférica

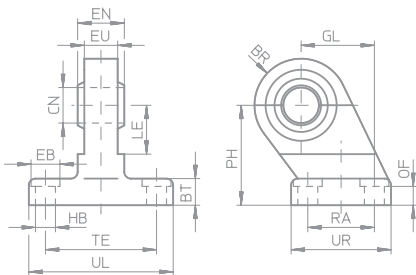

Symbol/Bore	32	40	50	63	80	100	125
BR	15	17	20	22	27	29	39
BT	10	10	12	12	14	15	20
ØCN	10	12	16	16	20	20	30
ØEB	11	11	14	14	17	17	19
EN	14	16	21	21	25	25	37
ER	15.5	17.5	20.5	22.5	28.5	29.5	39.5
EU	10.5	12	15	15	18	18	25
GL	21	24	33	37	47	55	70
HB	6.6	6.6	9	9	10	10	14
LE	16	20	24	27	31	38	50
OF	9	9	11	11	12.5	13.5	18.5
PH	32	36	45	50	63	71	90
RA	18	22	30	35	40	50	60
TE	38	41	50	52	66	76	94
UL	51	54	65	67	86	96	124
UR	31	35	45	50	60	70	90

Série CPME

• Garfo para Haste



Modelo "G"



Modelo "I"

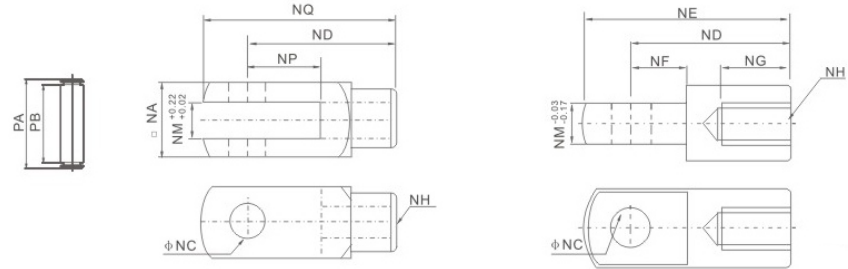

Modelo "G"

Modelo "I"

Symbol/Bore	32	40	50	63	80	100	125	160	200
NA	19	25.4	32	32	44.4	44.4	55	70	70
NC	10	12	16	16	20	20	30	35	35
ND	40	48	64	64	80	80	110	144	144
NE	52	67	89	89	112	112	155	201	201
NF	15	24	32	32	40	40	50	50	55
NG	20	20	23	23	30	30	56	72	72
NH	M10×1.25	M12×1.25	M16×1.5	M16×1.5	M20×1.5	M20×1.5	M27×2.0	M36×2.0	M36×2.0
NM	10	12	16	16	20	20	30	35	35
NP	20	24	32	32	40	40	54	72	72
NQ	52	62	83	83	105	105	148	191	191
PA	26.2	32.8	39.3	39.3	53.3	53.3	64	80	80
PB	20	26.5	33	33	45	45	55.6	70.6	70.6

• Munhão Frontal e Traseiro

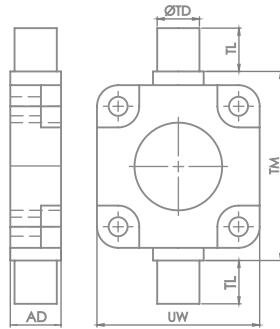

Symbol/Bore	32	40	50	63	80	100
AD	16	20	24	24	27	37
ØTD	12	16	16	20	20	25
UW	46	58	68	82	102	123
TL	12	16	16	20	20	25
TM	50	63	75	90	110	132

• Fixação tipo Flange

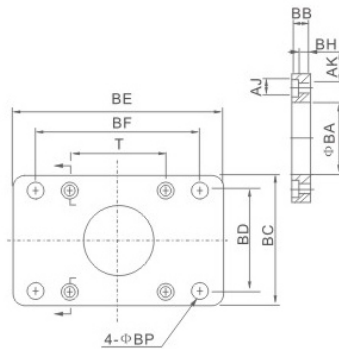

Symbol/Bore	32	40	50	63	80	100	125	160	200
AJ	11	11	14	14	17	17	19	25	25
AK	7	7	9	9	11	11	13	17	17
BA	30.5	35.5	40.5	45.5	45.5	55.5	60.5	65.5	75.5
BB	10	10	12	12	16	16	20	20	25
BC	47	53	65	75	95	115	140	180	220
BD	32	36	45	50	63	75	90	115	135
BE	80	90	110	125	154	186	224	280	320
BF	64	72	90	100	126	150	180	230	270
BH	4	4	4	6	6	6	8	8	12
BP	7	9	9	9	12.5	14.5	16.5	18.5	24
T	32.5	38	46.5	56.5	72	89	110	140	175

• Junta Flutuante

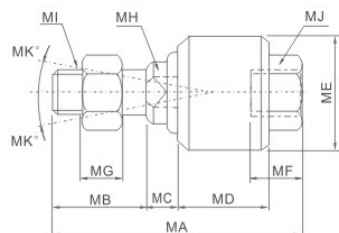

Symbol/Bore	MA	MB	MC	MD	ME	MF	MG	MH	MI	MK
32	58	22	7	21	26	11.5	7	10	M10×1.25	12
40	58	22	8	21	28	11.5	8	12	M12×1.25	12
50	90	27	10	41	44.5	20	10	17	M16×1.5	7
63	90	27	10	41	44.5	20	10	17	M16×1.5	7
80	102	29	13	46	53	24	13	22	M20×1.5	10
100	102	29	13	46	53	24	13	22	M20×1.5	10
125	147	54	13	64	62	39	14	30	M27×2.0	9
160	147	43	23	58	88	35	13.5	36	M36×2.0	15
200	147	43	23	58	88	35	13.5	36	M36×2.0	15

• Guia Linear



G
Modelo

Deslizante	
B	Bucha de latão
R	Rolamentos de esfera

Ø Cilindro
32
40
50
63
80
100

Cursos (mm)
10 à 500

Exemplo: GB32-100
GR80-220



Precauções

- A GHPC do Brasil não se responsabiliza pelo uso indevido, mau uso, do equipamento.
- A utilização de máquinas e equipamentos pneumáticos deve ser feita apenas por profissionais qualificados.
- Não exceder as especificações descritas no catálogo, afim de evitar danos à integridade física do produto e/ou operador.
- Garantir o total cuidado no manuseio e instalação do produto afim de evitar choques e/ou quedas à peça.
Caso venha acontecer, mesmo que aparentemente intacto, poderá ter causado danos à sua função.
- Garantir total limpeza dos tubos e conexões antes de serem conectados ao produto.
- Lubrificação NÃO NECESSÁRIA, independente do meio em que a peça esteja sendo utilizada. (Ex.: Poeira, foligens, etc.)